

LG Dynamic Braking Units ***SV-DBH Series***

Read this manual carefully before installing, wiring, operating, servicing or inspecting the DB unit.

Keep this manual within easy reach for quick reference.

Before handling the product

This manual describes the safety instructions that must be followed when installing, operating, and servicing. Read this manual completely before installing. The unit contains high voltage that can cause electric shock resulting in personal injury or loss of life.

SAFETY INSTRUCTIONS

- Always follow safety instructions to prevent accidents and potential hazards from occurring.
- In this manual, safety messages are classified as follows:



WARNING

Improper operation may result in serious personal injury or death.



CAUTION

Improper operation may result in slight to medium personal injury or property damage.

- Throughout this manual we use the following two illustrations to make you aware of safety considerations



Identifies potential hazards under certain conditions.
Read the message and follow the instructions carefully.



Identifies shock hazards under certain conditions.
Particular attention should be directed because dangerous voltage may be present.



WARNING

- **Do not remove the cover while power is applied or the unit is in operation.**
Otherwise electric shock could occur.
- **Do not run the DB unit with the front cover removed.**
Failure to comply could result in electric shock due to high voltage terminals or charged capacitor exposure.
- **Do not remove the cover except for periodic inspections or wiring, even if the input power is not applied.**
Otherwise, you may access the charged circuits and get an electric shock.

- **Wiring and periodic inspections should be performed at least 10 minutes after disconnecting the input power and after checking the DC link voltage is discharged with a meter (below DC 30V).**

Otherwise, you may get an electric shock.

- **Operate the switches with dry hands.**

Otherwise, you may get an electric shock.

- **Do not use the cable when its insulating tube is damaged.**

Otherwise, you may get an electric shock.

- **Do not subject the cables to scratches, excessive stress, heavy loads or pinching.**

Otherwise, you may get an electric shock.



CAUTION

- **Install the DB unit on a non-flammable surface. Do not place flammable material nearby.**

Otherwise, fire could occur.

- **Disconnect the input power if the inverter or DB unit gets damaged.**

Otherwise, it could result in a secondary accident and fire.

- **Do not connect the braking resistor directly to the DC terminal (P/B1, N) of the DB unit.**

Otherwise, fire could occur.

- **Do not touch DB unit, Inverter and the resistor right after the power is turned off.**

The resistor is still hot.

- **Do not allow lint, paper, wood chips, dust, metallic chips or other foreign matter into the DB unit.**

Otherwise, fire or accident could occur.

- **Do not apply power to a damaged inverter or to DB unit with missing parts even if the installation is complete.**

Otherwise, electric shock or fire could occur.

1. Nomenclature

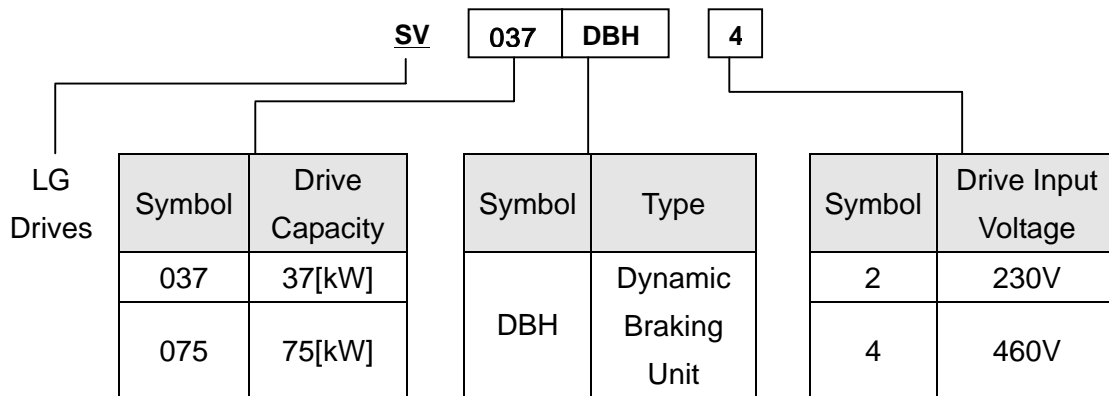

2. Specifications

Model Name	SV037DBH-2	SV037DBH-4	SV075DBH-4
Max. DC Input Volt.	DC 400V (200V Class)	DC 800V (400V Class)	
Applicable Drive Capacity	37[kW]	37[kW]	75[kW]
Braking Resistor	3 5kW	12 5kW	6 10W
Average Braking Torque	150%		
Enable Duty	5% ED		
Output Signal	Fault output contact, Slave control signal		
Protection (Trip)	Heat sink Over-heat, Over-current		
Environmental Conditions	Ambient Temperature	-10 ~ 40	
	Humidity	Under 90% RH (Non-condensing)	
	Altitude	Under 1,000m above sea level	
	Cooling	Self-cooling	

3. Installation

■ Environmental Conditions

- 1) Do not mount the unit in direct sunlight. Isolate the unit from excessive vibration.
- 2) Protect the unit from moisture, dust, metallic particles, corrosive gases and liquids. Install the units on a non-flammable material and as smooth as possible.
- 3) In case of installing many units in a panel, consider the air flows for power dissipation (see below figures for proper installation).

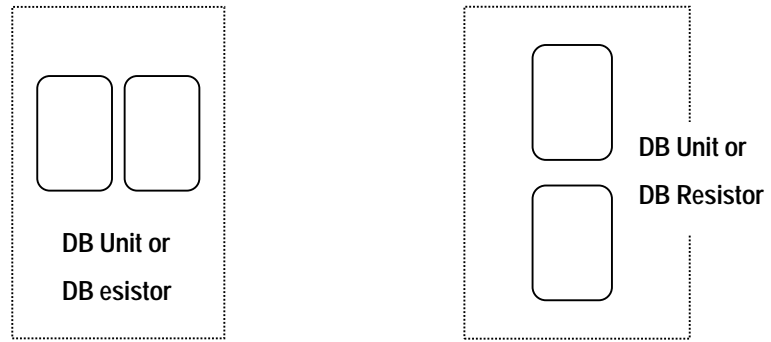

GOOD

BAD

<<Installing units in a panel>>

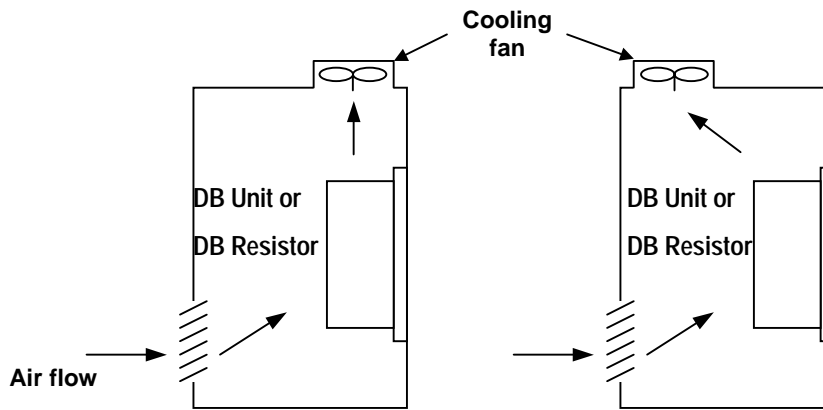

GOOD

BAD

<<Fan location in a panel>>

■ **Mounting**

The units must be mounted vertically with sufficient room (horizontally and vertically) from adjacent equipment.

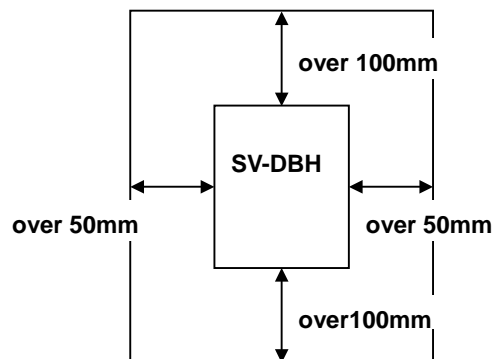

4. Terminal Configuration

1) Power Terminals

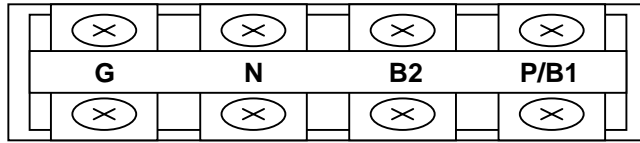

Terminal	Function
G	Ground
N	DC (-) input. Connect to "N" terminal of drive
B2	Connect to braking resistor
P/B1	DC (+) input. Connect to "P2" or "P" terminal of drive and connect to braking resistor

2) Control Terminals

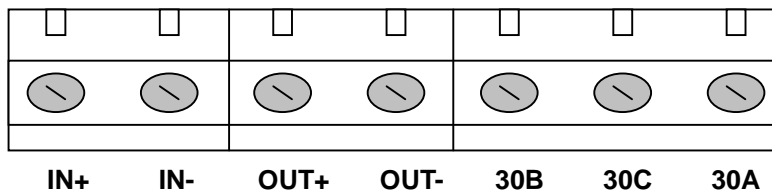

Terminal	Function
IN+	Slave turn on signal input (when "Slave Mode" selected)
IN-	Slave turn on signal input (when "Slave Mode" selected)
OUT+	Slave turn on signal output (when "Master Mode" selected)
OUT-	Slave turn on signal output (when "Master Mode" selected)
30A	Fault signal output
30B	30A : Normal open contact
30C	30B : Normal close contact, 30C : Common terminal

(Refer to sec. 7 for details of Master/Slave Operation)

5. Terminal Wiring

- The SV-iH series have two kinds of power terminal configurations. Make sure the wiring according to drive capacity.
- SV030iH-4, SV037iH-4, SV045iH-4, SV055iH-4 units (Non-UL type) do not provide terminals for DC reactor connection.

1) Wiring Drive, DB unit and DB resistor other than SV030/037/045/055iH-4U

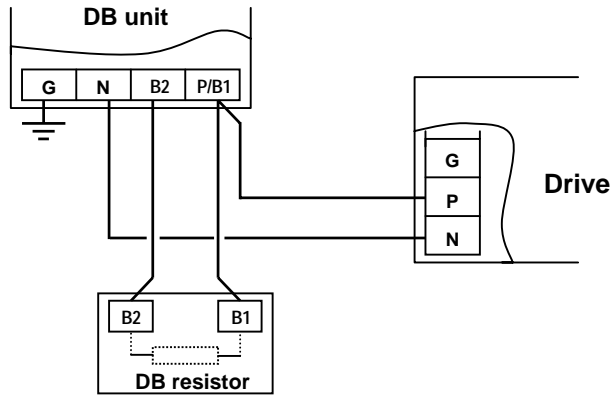

2) Wiring Drive, DB unit and DB resistor for SV030/037/045/055iH-4(Non UL type)

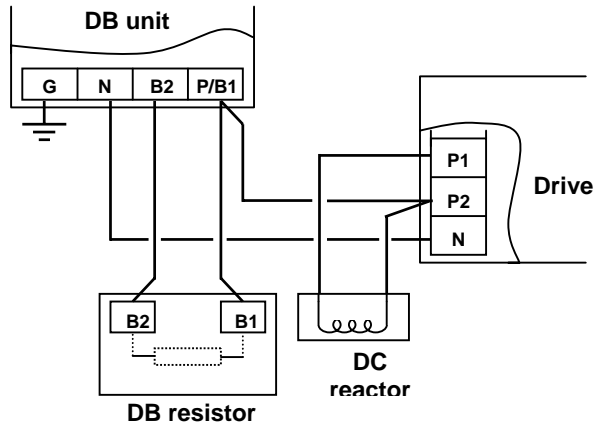

3) Wiring Drive, DB unit, DB resistor and DC reactor

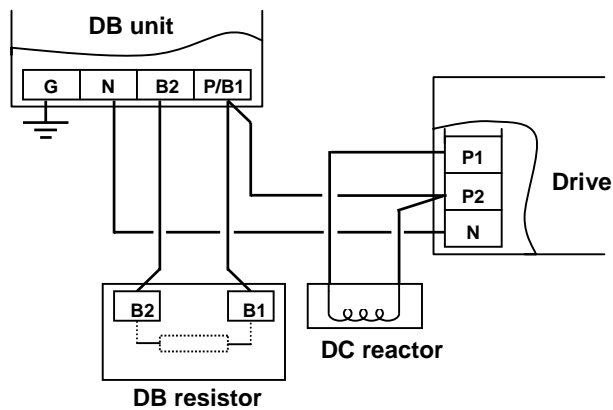

6. Basic Wiring

1) Single Operation

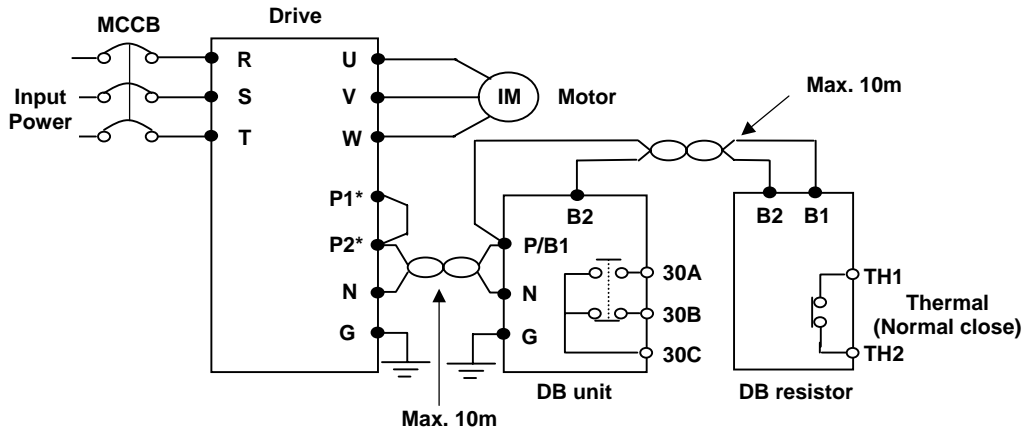

2) Master/Slave Operation

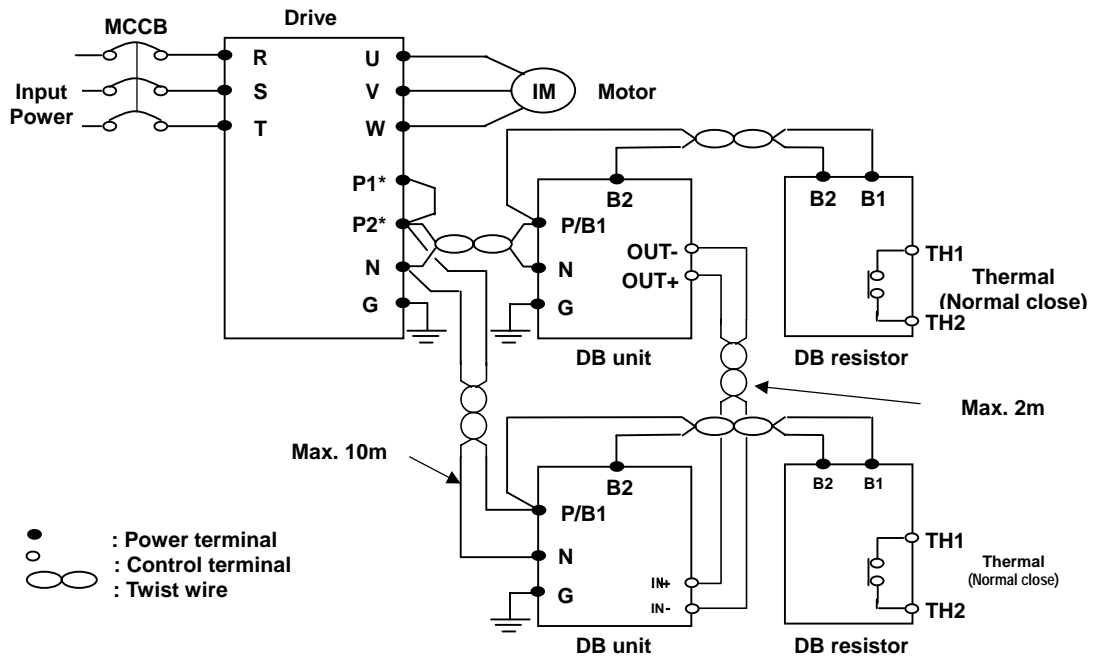

*) The SV030/037/045/055DBH-4 units provide only terminal “P” instead of terminal “P1” and “P2”. Please refer to “2) Wiring Drive, DB unit and DB resistor for V030/037/045/055iH-4” for correct wiring.

- Use twist wire shorter than 10m between drive, DB unit and DB resistor.
- In case of master/slave operation, the control wire should be shorter than 2m with twist wire.
- Be sure to earth terminal “G” of drive and DB unit.
- Wire Size:

DB units		Wire size
200V Class	SV037DBH-2	14 mm ² (AWG 6)
400V Class	SV037DBH-4	7.5 mm ² (AWG 8)
	SV075DBH-4	14 mm ² (AWG 6)

7. Master / Slave Operation

1) In case of parallel operation of two braking units, the one must be set at “Master” and the other at “Slave”.

(When one braking unit is operated it must be set at “Master”: Factory default – Master”)

2) How to set to Master (on PCB)

- Set the “Select Switch S1” as below figure.

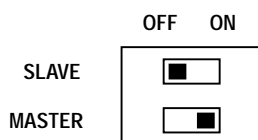

3) How to set to Slave (on PCB)

- Set the “Select Switch S1” as below figure.

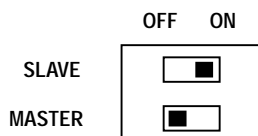

4) Connection between Master and Slave

- Connect “OUT+” terminal of Master to “IN+” terminal of Slave and “OUT-” terminal of Master to “IN-” terminal of Slave.

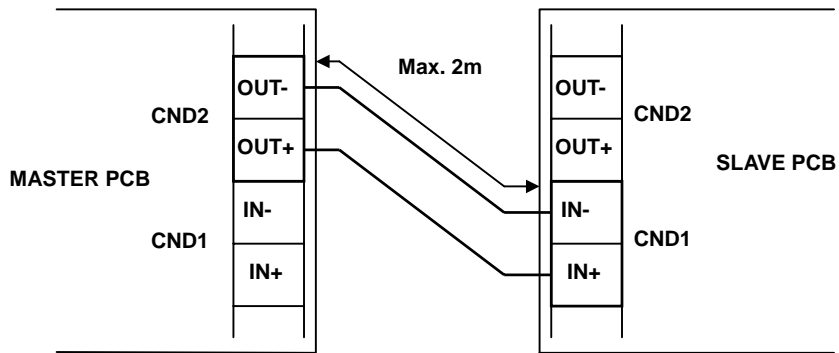

8. Combination of DB Units according to Drive Capacity

1) Combination of Braking Units (SV-iH Series)

■ 200V Class

Drive Type	SV030iH-2U	SV037iH-2U	SV045iH-2U	SV055iH-2U
Braking Unit	SV037DBH-2		SV037DBH-2 × 2 sets	
Braking Resistor	3 , 5kW		3 , 5W × 2 sets	
Applicable Motor	30kW	37kW	45kW	55kW

■ 400V Class

Drive Type	SV030 iH-4U	SV037 iH-4U	SV045 iH-4U	SV055 iH-4U	SV075 iH-4U	SV090iH ~ SV160iH-4U
Braking Unit	SV037DBH-4		SV075DBH-4			SV075DBH-4 × 2 sets
Braking Resistor	12 , 5kW		12 , 5kW × 2 sets			12 , 5kW × 4 sets
Applicable Motor	30kW	37kW	45kW	55kW	75kW	90kW ~160kW

● See below for the combination of DB Units and DB resistors.

● When using DB units above 160kW contact LGIS or your distributor.

2) Combination of 200V Class Units

Drive Capacity: 30[kW] ~ 37[kW]

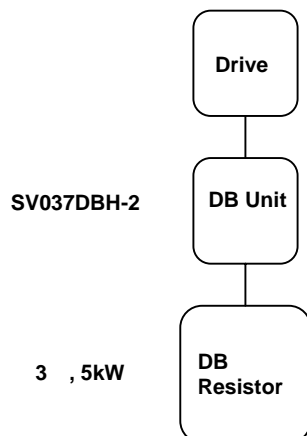

Drive Capacity: 45[kW] ~ 55[kW]

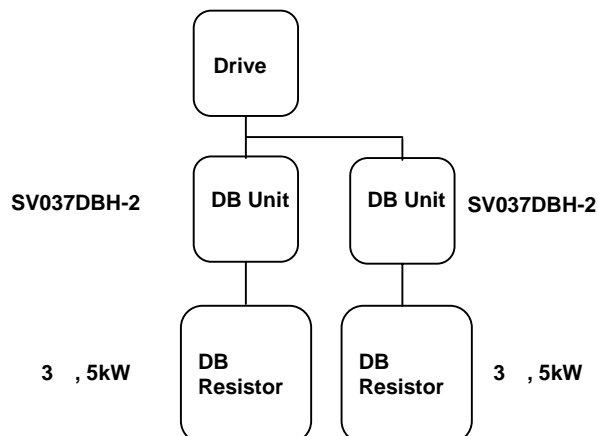

3) Combination of 400V Class Units

Drive Capacity: 30[kW] ~ 37[kW]

Drive Capacity: 45[kW] ~ 75[kW]

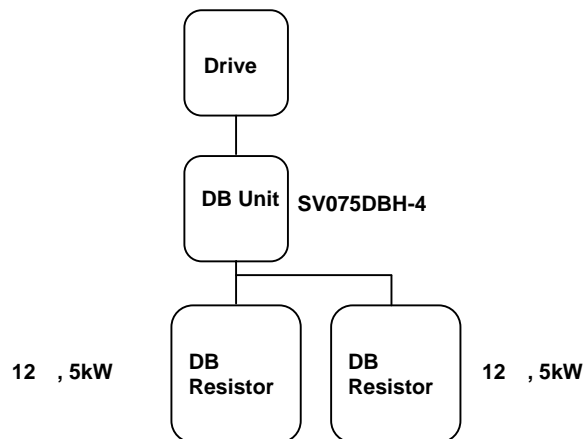
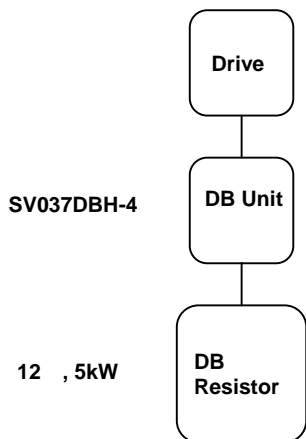

Drive Capacity: 90[kW] ~ 160[kW]

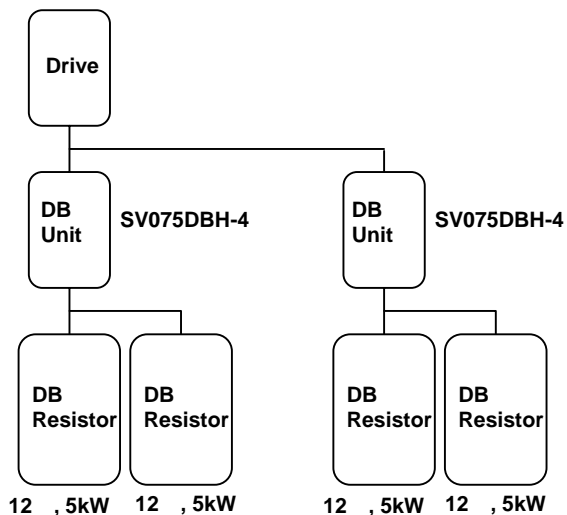

9. Display LED and Fault Reset

The DB Unit have four LEDs on the frontcover. The green LEDs display main power input and braking operation. The red LEDs display fault status of the unit.

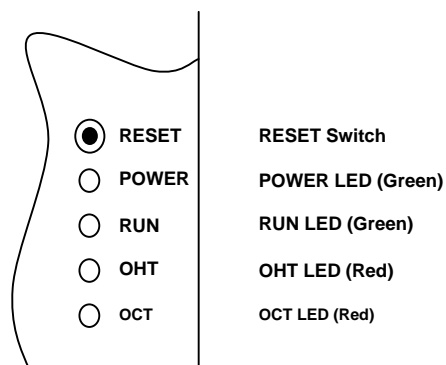

Display	Function
RESET	Reset the "OCT" fault of the unit.
POWER	This LED is turned on when the input power of the unit is introduced.
RUN	This LED is turned on when the unit is in the braking operation.
OHT	This LED is turned on and cut off (trip) the output when the heat sink of the unit is over heated.
OCT	This LED is turned on when an excessive current flows through the IGBT and the unit cut off the output to protect the unit

10. Dimensions

Units: [mm]

Net weight: 5.4 lbs

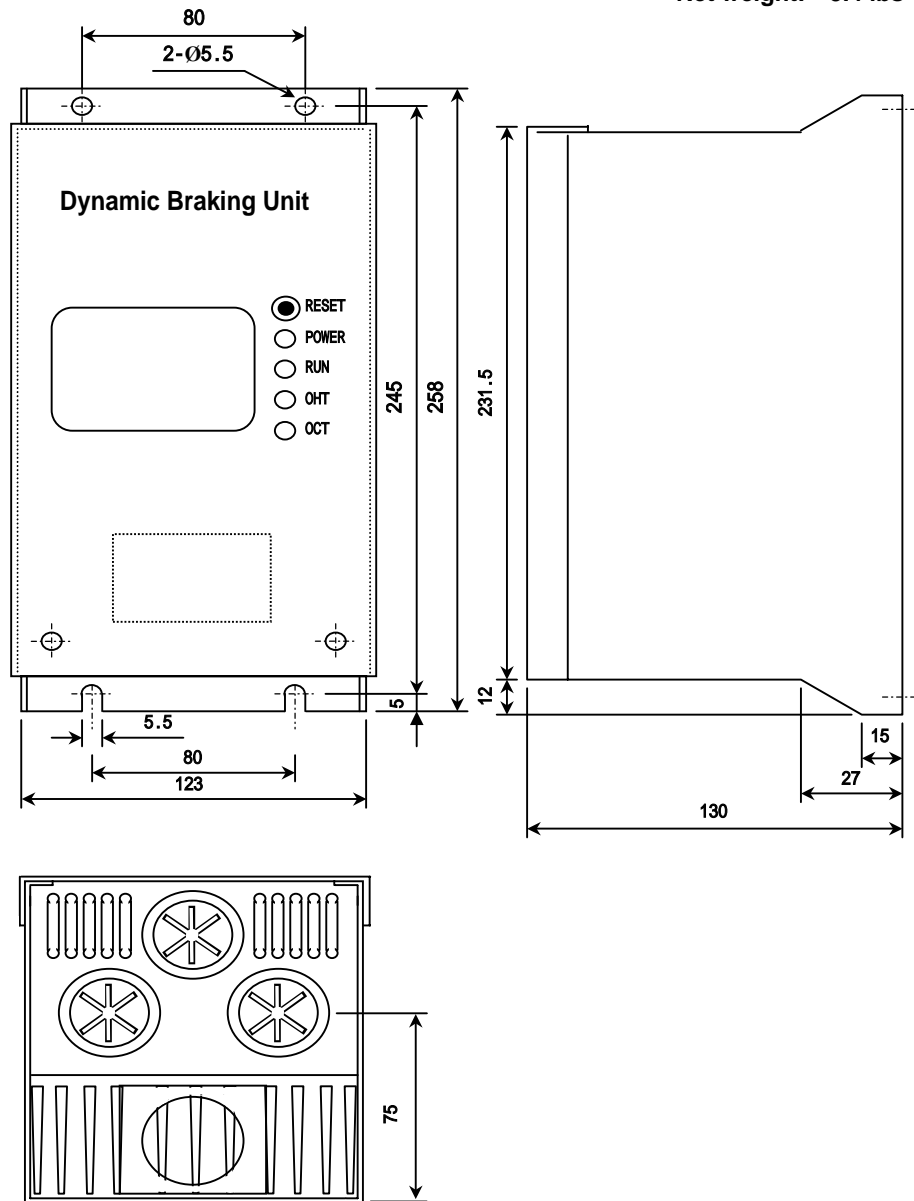



LG



LG Industrial Systems Co., Ltd.

LGIS constantly endeavors to improve its product so that information in this manual is subject to change without notice

Visit our Website! www.lgis.com

May, 2002

Publication #: 10310000359